

02-51-30

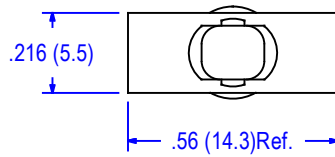
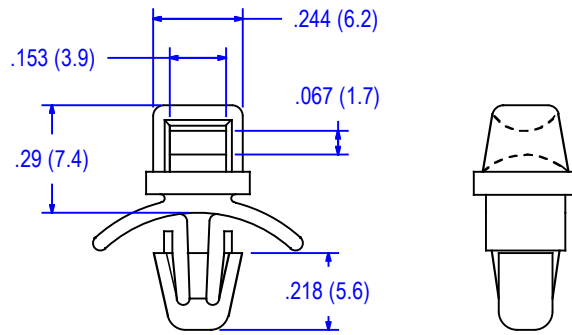

MOUNTING HOLE DIAMETER : .187±.003 (4.75±0.08).  
 PANEL THICKNESS : .032 - .078 (0.79-1.98).

ACCEPTS CABLE TIES FROM 18 lb to 40 lb.

PACKAGING : 500 PER BAG

UL 94V-O MATERIAL AVAILABLE UPON REQUEST  
 TO ORDER ADD SUFFIX "X" TO ITEM NUMBER

|                          |                            |
|--------------------------|----------------------------|
| MATERIAL                 | NYLON 66                   |
| UL RATING                | 94V-2                      |
| UL FILE NO.              | E41938                     |
| COLOR                    | NATURAL                    |
| RoHS COMPLIANCE          | YES                        |
| TEMPERATURE RANGE (REF.) | -40 to 185°F (-40 to 85°C) |
| MR NUMBER                | 12                         |

|           |                 |             |              |  |    |   |                           |
|-----------|-----------------|-------------|--------------|--|----|---|---------------------------|
|           |                 |             |              |  | BY | DATE  | Title                     |
|           |                 |             |              |  |    |   | <b>CABLE TIE HOLDER</b>   |
|           |                 |             |              |  |    |   | Part No. <b>02-51-30</b>  |
|           |                 |             |              |  | FL | 10/3/20   | Issue <b>0</b>            |
|           |                 |             |              |  |    |   | 10/3/20                   |
|           |                 |             |              |  |    |   | Drwg. type <b>Catalog</b> |
|           |                 |             |              |  |    |   | File No. <b>02-51-30</b>  |
| <b>No</b> | <b>Revision</b> | <b>Date</b> | <b>Init.</b> |  |    | <b>ALL ELECTRONICS HARDWARE INC.</b><br>2642 CORPORATE PARKWAY<br>ALGONQUIN, ILLINOIS . 60102<br>1-800-778-7234 |                           |